

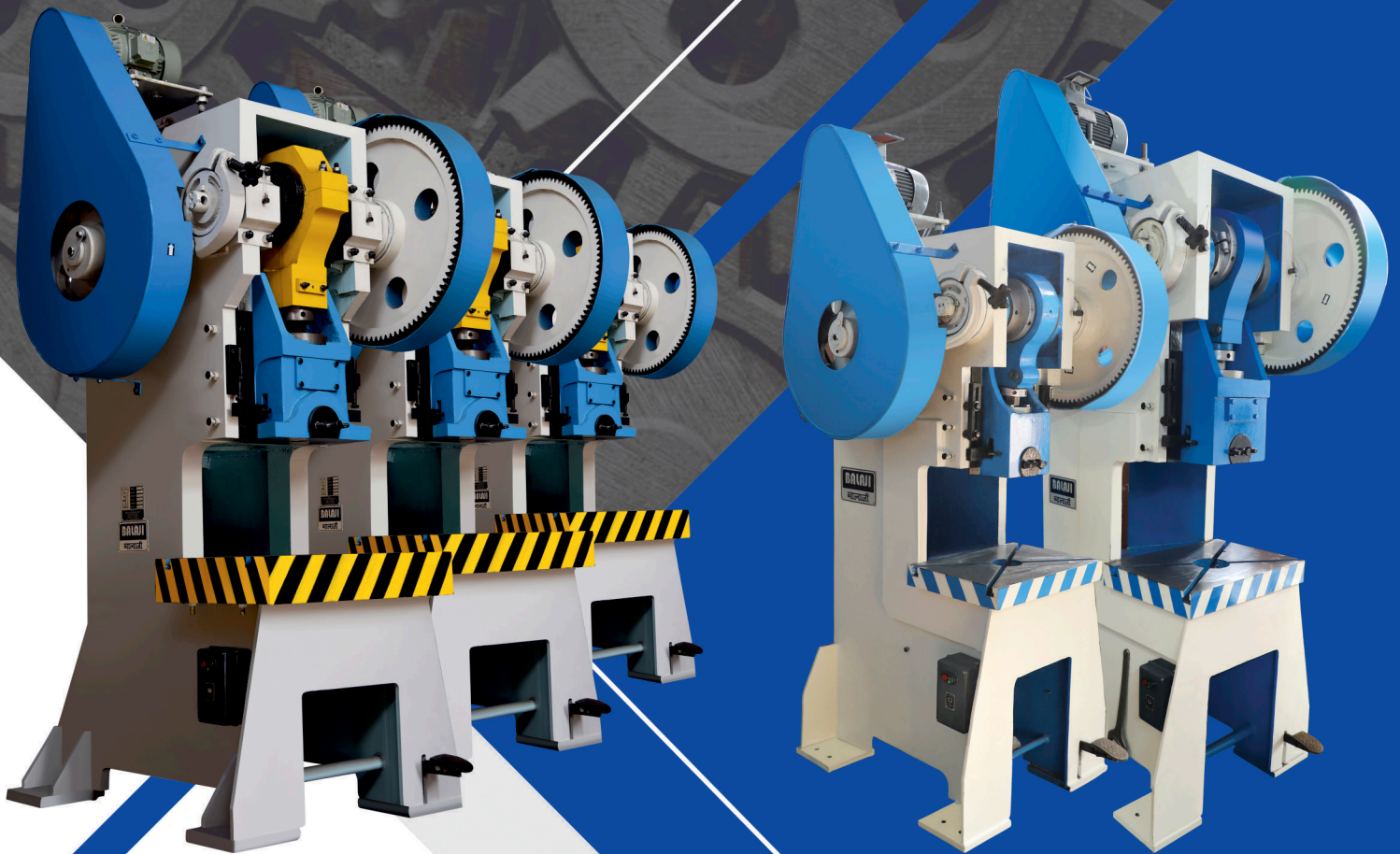

ISO Certified 9001 : 2015

PNEUMATIC CLUTCH
& ROLLING KEY

Power
PRESSES



BETTER
QUALITY, COST, DELIVERY, SERVICE



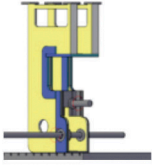

FRAME

All presses frames are fabricated from extra high tensile steel plate and Reinforced by heavy ribbing assure the least deflection against full load. The Frame element are thermally stress relieved for maintaining accuracy over.

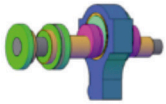

CRANK SHAFT & BEARING

Eccentric shaft is machined from normalized carbon steel forged. It has been ground finished on bearing surface. Heavy walled phosphorus bronze bearings use for long run.

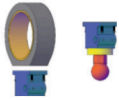

SLIDE & GUIDES

Heavy duty cast iron slide runs in long cast iron guides and bearing surface of slide guides slide face and bed of each press are hard scraped and provides smooth movement of slide square to the table geometrical alignment to I.S.I. / Prof. SCHLESINGER'S limits of accuracy.

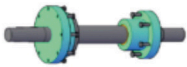

CLUTCH & BRAKE

A heavy duty dynamically balanced single disk combined clutch and brake unit is used for a continuous jolt free strokes and reduce noise. One board mounting provides easy accessibility for maintenance.



PRESS LUBRICATION

All presses are equipped with centralized on shot lubrication system to all important Point.



ELECTRICAL

All Standard make electrical are used and are simple and safe. Provide complete safety for machine and operators.

OPTIONAL ACCESSORIES

- Hydraulic Overload Safety
- Pneumatic Die Cushion
- Motorized Lubrication Device
- Photo Electrical Safety Device
- Die Lifter
- Variable Speed
- Inclinable Mechanisms
- Auto Lubrication Grease Pump

STANDARD ACCESSORIES

- Main Motor, Control Panel
- Shot Lubrication Device
- Knockout Bar (Mechanical)
- Production Counter
- Dual Solenoid Valve (Above 100 Ton)
- Three way Rotary cam limit switch
- Operation : Inching, Single Cycle and Continuous Cycle



SBB-50L TON

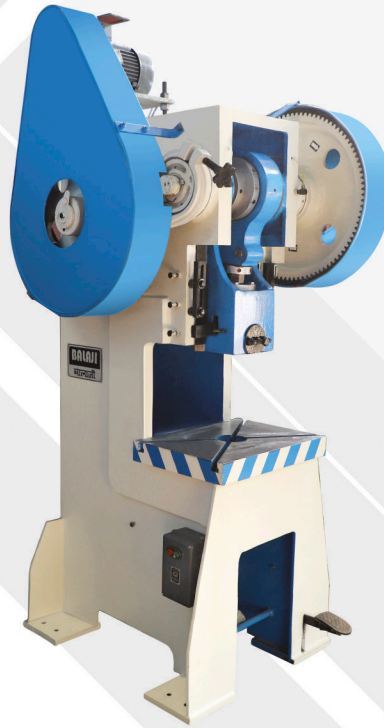

SBB-30L TON

'BALAJI' SBB STANDARD SERIES PRESSES

- › Cost Efficient
- › Attractive Design
- › Good Accuracy
- › Low Maintenance

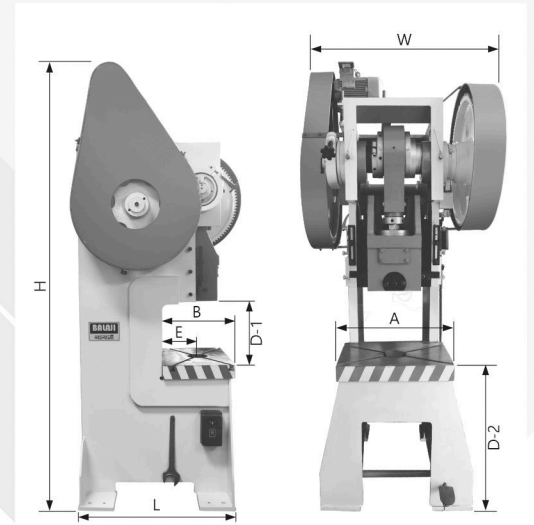

SPECIFICATION OF STEEL BODY, GEARED STRAIGHT SIDE 'C' FRAME POWER PRESSES

TECHNICAL SPECIFICATIONS:	SBB-5L Ton	SBB-10L Ton	SBB-20L Ton	SBB-30L Ton	SBB-50L Ton
Crank Shaft Dia	Ø57mm	Ø62mm	Ø65mm	Ø82mm	Ø102mm
Stroke Fixed	32mm	40mm	50mm	60mm	80mm
Adj. Stroke Length	5-32mm	5-40mm	5-50mm	5-60mm	5-80mm
Hole In Ram (Dia X Depth)	25x40mm	25x40mm	32X45mm	44x50mm	50x65mm
Hole In Bed	75mm	100mm	120mm	140mm	160mm
Bed Area (A x B)	400x250mm	450x300mm	500x325mm	550x400mm	650x475mm
Shut Height	228mm	240mm	240mm	270mm	325mm
S.P.M	70	70	70	60	50
Center To Back (E)	125mm	140mm	160mm	200mm	255mm
Distance Between Bed To Ram(D-1)	260mm	280mm	290mm	330mm	405mm
Floor To Top Of Bed (D-2)	650mm	670mm	800mm	800mm	900mm
Total (HXLXW)	1350x575x780mm	1450x635x850mm	1685x725x970mm	1950x840x1170mm	2580x1140x1420mm
Electric Motor	1HP/1440	1HP/1440	2HP/1440	3HP/1440	5HP/1440
Weight Net (Approx)	480 kg	780 kg	1050 kg	1500 kg	2550 kg

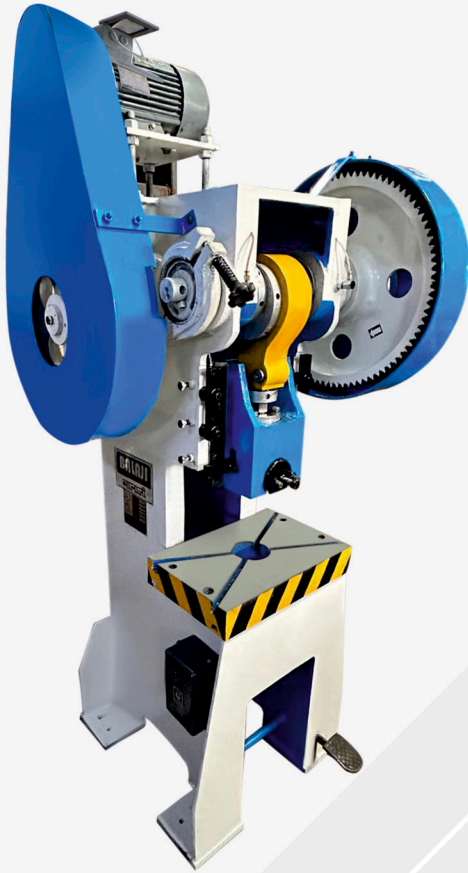

BSP-25 TON

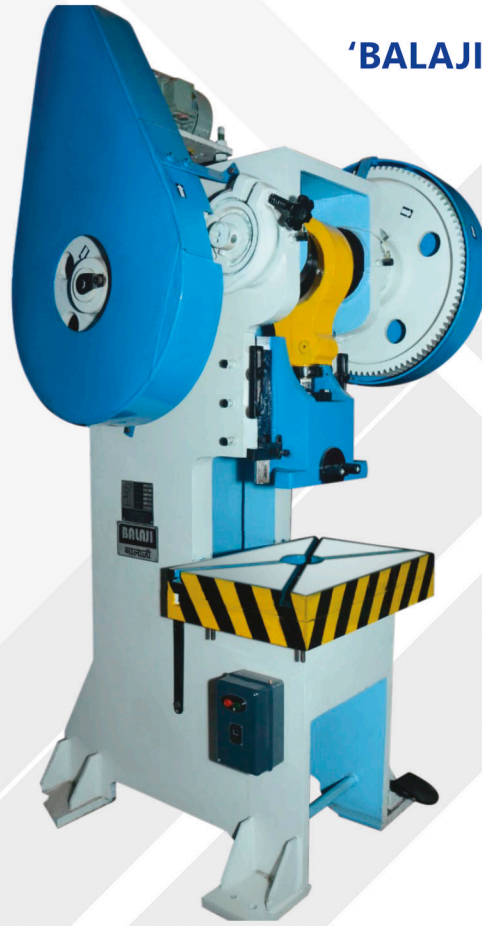

BSP-35 TON

'BALAJI' BSP EXTRA HEAVY DUTY SERIES PRESSES

- Heavy Duty ☺
- Excellent Durability ☺
- Heavier in Weight ☺
- Better Reserve Capacity ☺

SPECIFICATION OF STEEL BODY, GEARED 'C' FRAME OBI/NON INCLINABLE POWER PRESSES

'BALAJI' MAKE HEAVY DUTY STEEL FABRICATED GEARED & UN-GEARED ROLLING KEY POWER PRESS FITTED WITH STANDARD MAKE ELECTRIC MOTOR, MOTOR PULLEY, STARTER, VEE-BELTS, LUBRICATION DEVICE, COMPLETE WITH FLEXIBLE PIPE WIRING, FLYWHEEL AND GEAR GAURDS, BALL SCREW SPANNERS AS PER REQUIRED SPECIFICATIONS.

TECHNICAL SPECIFICATIONS:	BSP-25 Ton	BSP-35 Ton	BSP-60 Ton
Crank Shaft Dia	Ø75mm	Ø87mm	Ø110mm
Stroke Fixed	60mm	70mm	100mm
Adj. Stroke Length	5-60mm	5-70mm	5-100mm
Hole In Ram (Dia x Depth)	32x45mm	44x50mm	50x65mm
Hole In Bed	140mm	190mm	240mm
Hole In Bolster	90mm	100mm	125mm
Bed Area (A x B)	540x365mm	630x430mm	780x530mm
Shut Height	240mm	285mm	335mm
SPM	70	60	50
Center to Back (E)	160mm	200mm	255mm
Distance Between Bed To Ram (D-1)	300mm	355mm	435mm
Floor To Top of Bed (D-2)	800mm	800mm	900mm
Total (H x L x W)	1900x810x1120mm	2500x1100x1350mm	2600x1120x1400mm
Electric Motor	2HP/1440mm	3HP/1440	5HP/1440
Weight Net (Approx)	1250 kg	1900 kg	3300 kg

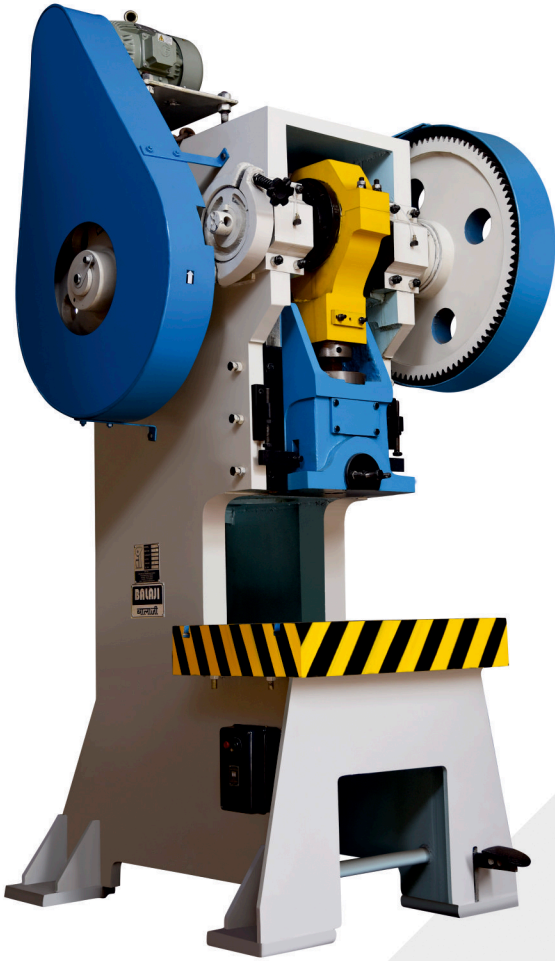

BSP-110 TON

'BALAJI' BSP EXTRA HEAVY DUTY SERIES PRESSES

- › Heavy Duty
- › Excellent Durability
- › Heavier in Weight
- › Better Reserve Capacity

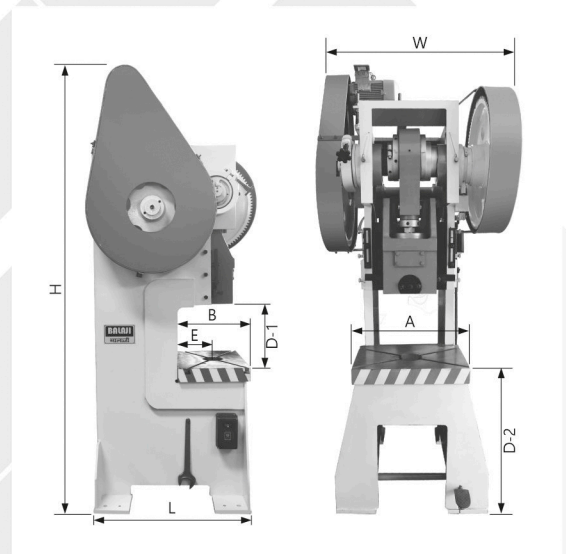

SPECIFICATION OF STEEL BODY, GEARED 'C' FRAME OBI/NON INCLINABLE POWER PRESSES

'BALAJI' MAKE HEAVY DUTY STEEL FABRICATED GEARED & UN-GEARED ROLLING KEY POWER PRESS FITTED WITH STANDARD MAKE ELECTRIC MOTOR, MOTOR PULLEY, STARTER, VEE-BELTS, LUBRICATION DEVICE, COMPLETE WITH FLEXIBLE PIPE WIRING, FLYWHEEL AND GEAR GAURDS, BALL SCREW SPANNERS AS PER REQUIRED SPECIFICATIONS.

BSP-80 Ton	BSP-110 Ton	BSP-160 Ton	BSP-200 Ton	BSP-250 Ton
Ø130mm	Ø150mm	Ø180mm	Ø200mm	Ø225mm
120mm	150mm	150mm	150mm	150mm
5-120mm	5-150mm	5-150mm	10-150mm	10-150mm
50x65mm	63x75mm	T-Slot Plate	T-Slot Plate	T-Slot Plate
270mm	350mm	360mm	360mm	360mm
145mm	160mm	165mm	165mm	165mm
800x600mm	1000x665mm	1050x700mm	1100x720mm	1100x750mm
350mm	420mm	450mm	450mm	480mm
45	40	35	30	25
265mm	315mm	320mm	320mm	325mm
470mm	570mm	600mm	650mm	680mm
900mm	900mm	900mm	900mm	900mm
2800x1250x1530mm	2950x1350x1650mm	3100x1500x1800mm	3200x1650x1950mm	3400x1800x2100mm
7.5HP/1440	10HP/1440	15HP/1440	20HP/1440	25HP/1440mm
4500 kg	6500 kg	9250 kg	11500 kg	15000 kg

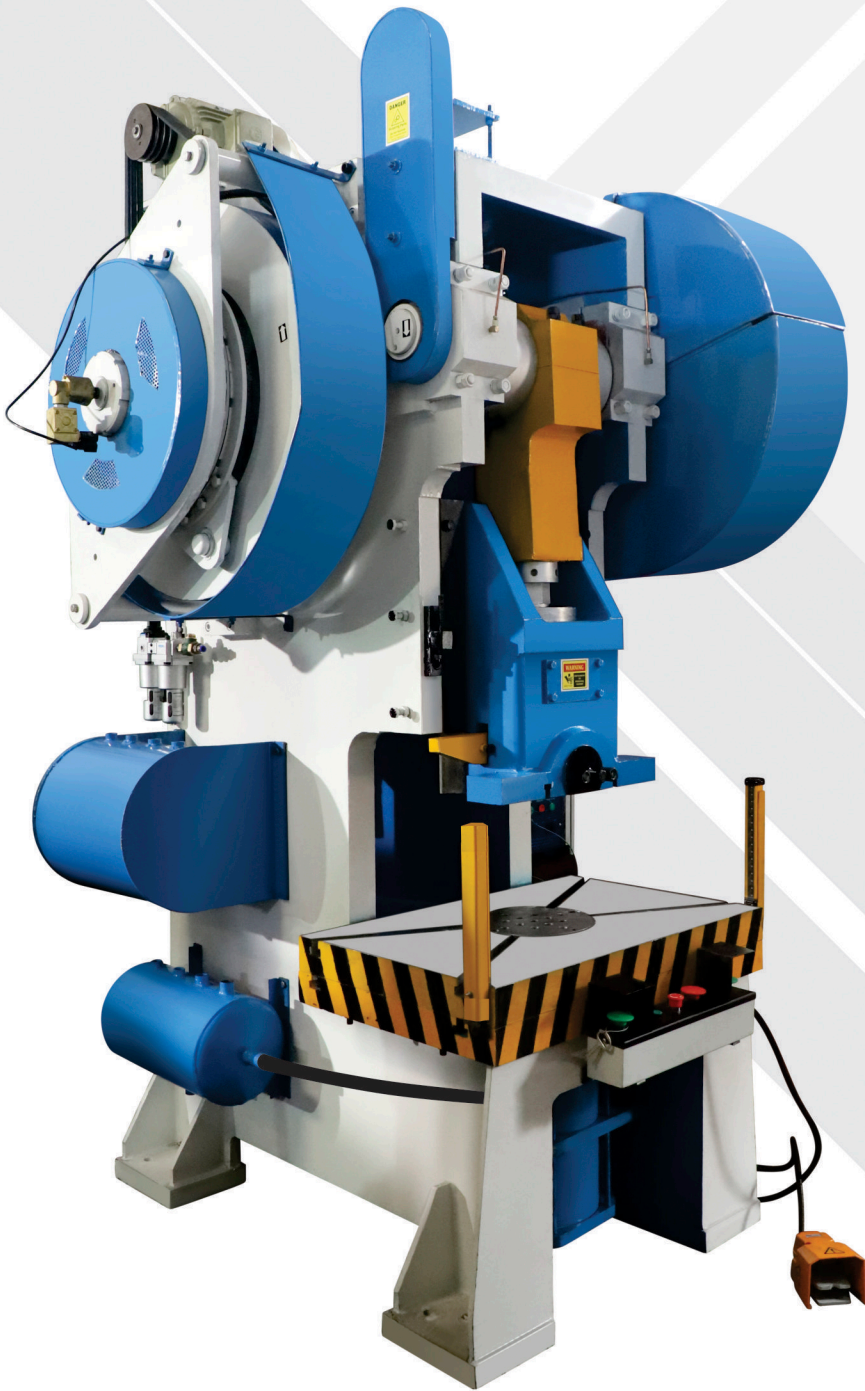

BSP-N-110 TON

'BALAJI' 'C' TYPE PNEUMATIC CLUTCH POWER PRESSES

- › More Reliable
- › More User Friendly
- › Extra Safety
- › Better Technology

STANDARD ACCESSORIES

- Air Clutch
- Air Tank
- FRL Unit
- Solenoid Valve
- Router Seal
- Rotary Cam Limit Switch
- Electric Panel
- Electric Panel with remote two hand control system
- Foot Switch Complete with PVC Channel Wiring
- Auto Lubrication Device

OPTIONAL ACCESSORIES

- Hydraulic Overload Safety
- Pneumatic Die Cushion
- Photo Electrical Safety Device
- Die Lifter
- Variable Speed
- Inclinable Mechanisms
- Auto Lubrication Grease Pump

CAPACITY RANGE - 25 Ton To 250 Ton

"Balaji" make heavy duty steel fabricated geared 'C' / 'H' Type frame pneumatic Clutch power press fitted with standard make electric motor, panel, Pneumatic clutch and brake with 'start' & 'off' option, clutch can be set To 'inching', 'continous', 'single stroke' & reversing option with two palm Buttons or by foot switch complete with vee belts, flexible pipe wiring, Flywheel and gear guards, ball screw spanner Tommey bar, As per following specifications:

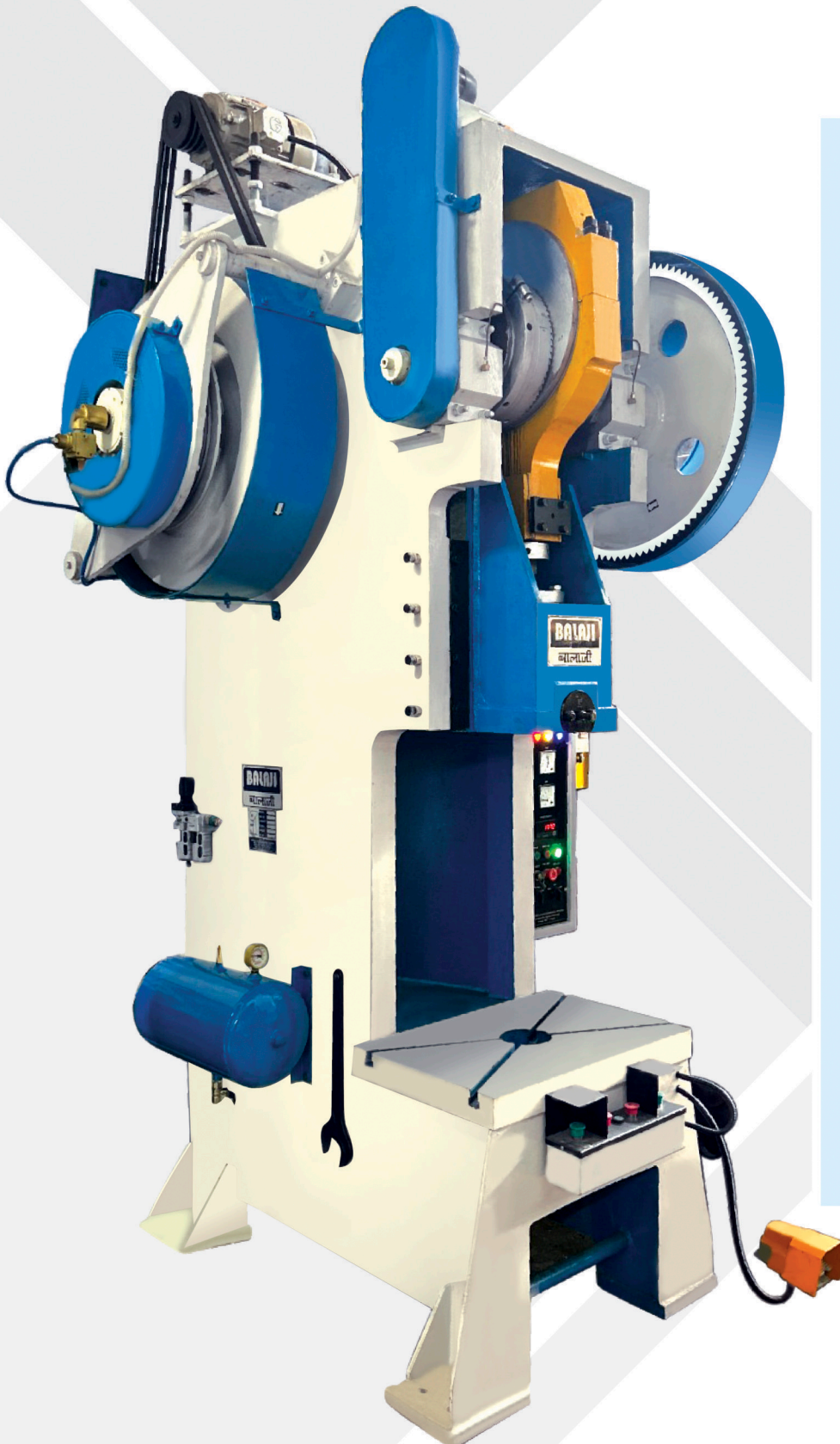

'BALAJI' 'C' TYPE SPECIAL CUSTOMIZED POWER PRESSES

We are specialized in designing and manufacturing Special purpose Mechanical Power Presses. According to Specific Customer required:-

Features:-

1. Customized Bed Sizes
2. Single, Double & Triple Geared Power Press
3. 5 mm to 500 mm Stock Length
4. Speed Control
5. Die Cushioning
6. Safety Features

Applications:-

Ideal for unique Stamping, Forming, Punching, Blanking & Drawing OR Any other Metal working Applications as Specified by the Customers.



BSS-150 TON



BSS-100 TON

**'BALAJI' 'H' TYPE
EXTRA HEAVY DUTY
SERIES PRESSES**

- Heavy Fabricated Frame
- Cost Efficient
- Attractive Design
- Low Maintenance

Balaji' make heavy duty steel fabricated geared Motorised rolling key H-type power press fitted with Electric motor, starter, vee-belts, lubrication pump, Bolster plate complete with flexible pipe wiring, Flywheel and gear gaurds & ball screw spanners.

SPECIFICATION OF STEEL BODY, GEARED STRAIGHT SIDE 'H' FRAME POWER PRESSES

Model		BSS-50	BSS-75	BSS-100	BSS-150	BSS-200	BSS-250	BSS-300	BSS-400
Capacity KN	MM	500	750	1000	1500	2000	2500	3000	4000
Stroke Fixed	MM	80	100	120	150	175	200	250	250
Variable Stoke (optional)	MM	10-80	10-100	10-120	10-150	10-150	10-150	10-150	10-150
Size of Bolster (LR x FB)	MM	470x470	550x550	600x650	700x700	800x800	900x900	1000x1000	1100x1200
Opening in Bolster	MM	125	145	160	160	160	170	180	200
Opening in Bed	MM	175	200	225	250	300	350	350	350
Distance Between Bed to Ram (As Per Stroke Fixed)	MM	330	350	420	520	575	700	700	750
Shut Height (Adj-up-stroke-down)	MM	250	250	300	370	400	500	500	500
S.P.M		50	45	40	35	30	25	25	20
Floor to Top of Bolster	MM	800	800	800	800	800	900	900	900
Electric Motor	HP/RPM	5/1440	7.5/1440	10/1440	15/1440	20/1440	25/1440	30/1440	40/1440
Weight Net (Approx)	KG	2300	3250	5000	6500	8500	11000	13000	17000

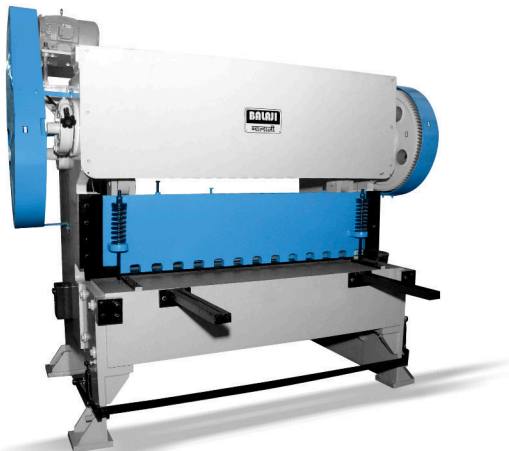

Over Crank Shearing Machine

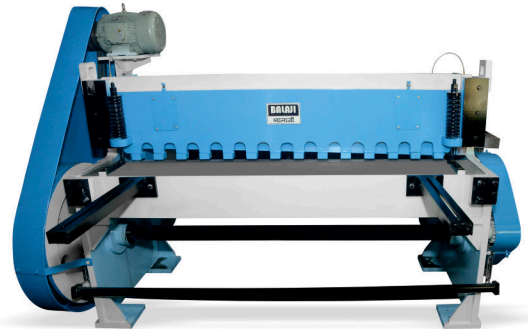

Under Crank Shearing Machine

"BALAJI"

Power Operated Guillotine Shearing machines are sturdily constructed and are designed for accuracy and dependability.

SIDE FRAMES:

Are of solid steel plates designed for maximum rigidity to eliminate deflection and to withstand continuous high speed performance at full capacity.

BED OR TABLE:

Is of closed box type construction, which forms a rigid backbone for the shear and a solid backing for the lower knife. additional ride under the table adds to its strength.

CUTTER BEAM:

The ram is of solid steel plates, accurately machined. The ram brace is bolted to the ram to adjust the camber which may result after long use. The ram move in taper guides, this facilities makes. The adjustment of clearance between Ram & table easien for cutting various thicknesses. Thus giving smooth shearing action.

CRANKSHAFT:

Is of forged carbon steel, accurately machined and runs in gun metal bushes, Flywheel Shaft runs in ball bearings.

HOLD DOWN:

Steel fabricated and is used for clamping the plate securely to the table while being cut. Spring loaded mechanical hold down is provided in all machines. how ever, in machines of 6mm capacity & above, pressure arms fitted to the cross support, are provided for additional grip, before cutting.

BLADES:

Four edges Hardened & Grinded D₂ Steel blades are provided.

ROLLING KEY CLUTCH:

Made of alloy steel for positive engagement and continuous operation, having three key way in the EN-8 insert.

BRAKE:

Constant spring loaded adjustable brake is provided.

GAUGES:

Rigid and accurate construction of back guage provides consistent widths of sheets to be cut.

TECHNICAL SPECIFICATION OF SHEARING M/C

MODEL	Thickness (mm)	Length (mm)	length Between Housing (mm)	Depth in Gap Frame (mm)	Number Of Stroke Per Minute	Cutting Angle	Max Back Guage ADI. (mm)	Motor (HP)	Weight Net (Kg.)
UC/750 X 4	4	750	1050	100	50	2°	600	3	1800
UC/1250 X 4	4	1250	1600	100	50	2°	600	5	2300
UC/1500 X 4	4	1500	1850	100	50	2°	600	7.5	2800
UC/2000 X 4	4	2000	2350	100	50	2°	600	7.5	3800
UC/2500 X 4	4	2500	2850	100	50	2°	600	10	4200
UC/3125 X 4	4	3125	3550	100	40	2°	600	15	5200
OC/1250 X 6	6	1250	1550	100	45	2°	600	7.5	4000
OC/1250 X 8	8	1250	1550	100	45	2.3°	600	10	4300
OC/1500 X 6	6	1500	1800	100	45	2.3°	600	10	4500
OC/1500 X 8	8	1500	1800	100	45	2.3°	600	12.5	4900
OC/2000 X 6	6	2000	2300	100	45	2.3°	600	15	5600
OC/2000 X 8	8	2000	2300	100	45	2.3°	600	15	6100
OC/2500 X 6	6	2500	2750	100	45	2.3°	600	15	6300
OC/2500 X 8	8	2500	2750	100	45	2.3°	600	15	6700
OC/3125 X 8	8	3200	3500	100	40	2.3°	600	25	8000



STANDARD ACCESSORIES

- Air Clutch
- Air Tank
- FRL Unit
- Solenoid Valve
- Router Seal
- Rotary Cam Limit Switch
- Electric Panel
- Electric Panel with remote two hand control system
- Foot Switch Complete with PVC Channel Wiring
- Auto Lubrication Device

PRESSING CYCLE FOR SINGLE LEVEL PART :

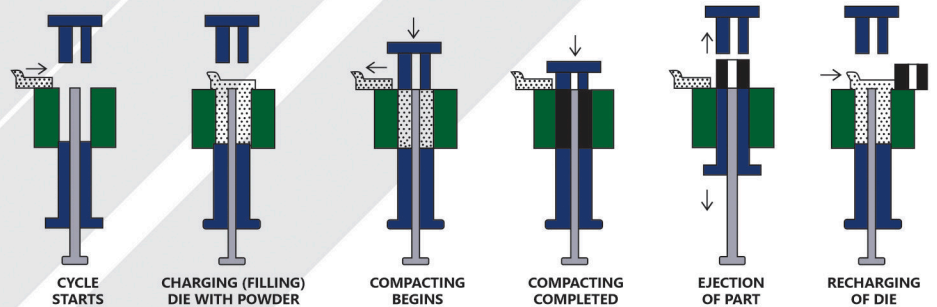

TECHNICAL SPECIFICATION :

"BALAJI" MAKE HEAVY DUTY STEEL FABRICATED GEARED MOTORISED POWDER COMPACTING MACHINE FITTED WITH STANDARD MAKE ELECTRIC MOTOR, PANEL, PNEUMATIC CLUTCH & BRAKE WITH 'START' & 'OFF' OPTION, CLUTCH CAN BE SET TO 'INCHING' 'CONTINUOUS' 'SINGLE STROKE' & REVERSING OPTION, THE DRUM CAM CAN BE SET TO CONCIDE WITH TIME IN DELAY OR ADVANCE OF FEEDER IN RESPECT TO PUNCH MOVEMENT COMPLETE WITH VEE BELTS, FLEXIBLE PIPE WIRING, AUTO LUBRICATION DEVICE, FLYWHEEL AND GEAR GUARDS AS PER REQUIRED SPECIFICATIONS.

VARIANTS	10 Ton	30 Ton	40 Ton
Maximum Pressure From Top	10 Tons	30 Tons	40 Tons
Maximum Pressure From Bottom	7 Tons	21 Tons	28 Tons
Maximum Fill Depth	60 mm	76 mm	100 mm
Maximum Dia of Parts	25 mm	32 mm	40 mm
Top Punch Stroke	70 mm	100 mm	100 mm
Bottom Punch Compression Stroke	0 to 20 mm	20 mm	35 mm
Top Punch Adjustment	0 to 15 mm	35 mm	35 mm
Ejection Stroke	60 mm	76 mm	100 mm
Motor H.P.	5 H.P.	10 H.P.	15 H.P.
No. of Stroke	6 to 20	6 to 30	6 to 30
Overall Dimension	Height	2000 mm	2250 mm
	Width	1200 mm	1500 mm
	Depth	1500 mm	2000 mm

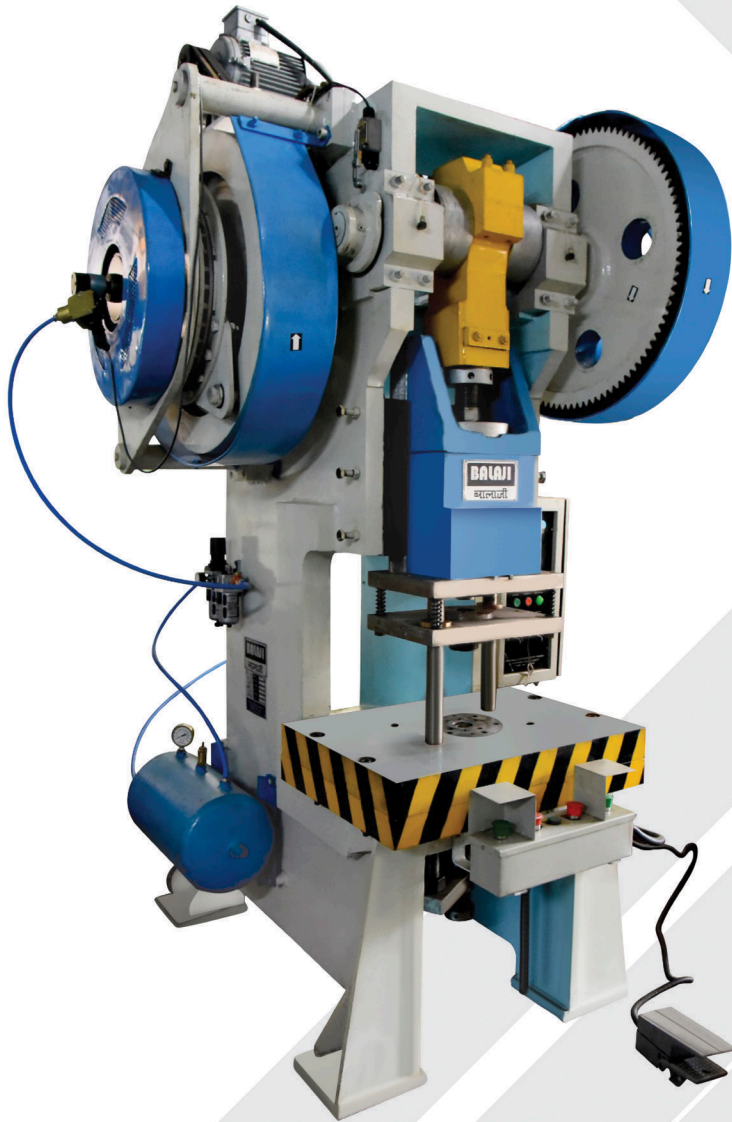

STANDARD ACCESSORIES

- Air Clutch
- Air Tank
- FRL Unit
- Solenoid Valve
- Router Seal
- Rotary Cam Limit Switch
- Electric Panel
- Electric Panel with remote two hand control system
- Foot Switch Complete with PVC Channel Wiring
- Auto Lubrication Device

BALAJI TOOL RIG FIXTURES MOUNTED ON PRESS :

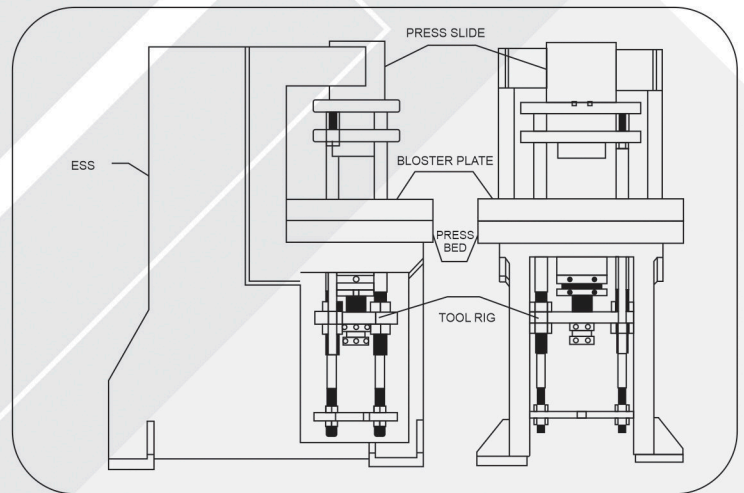

TECHNICAL SPECIFICATION :

"BALAJI" MAKE HEAVY DUTY STEEL FABRICATED GEARED MOTORISED SIZING MACHINE FITTED WITH STANDARD MAKE ELECTRIC MOTOR, PANEL, PNEUMATIC CLUTCH AND BRAKE WITH 'START' & 'OFF' OPTION, CLUTCH CAN BE SET TO 'INCHING' 'CONTINUOUS' 'SINGLE STROKE' & REVERSING OPTION WITH TWO PALM BUTTONS OR BY FOOT SWITCH COMPLETE WITH VEE BELTS, FLEXIBLE PIPE WIRING, AUTO LUBRICATION DEVICE, FLYWHEEL AND GEAR GUARDS, BALL SCREW SPANNER TOMMEY BAR, AUTO LUBRICATION DEVICE AS PER REQUIRED SPECIFICATIONS.

VARIANTS	10 Ton	20 Ton	30 Ton	40 Ton	50 Ton	75 Ton	100 Ton
Stroke Length Fixed	70 mm	80 mm	100 mm	100 mm	125 mm	150 mm	150 mm
Shut Height (AUSD) from Bolster	180 mm	200 mm	220 mm	250 mm	275 mm	300 mm	325 mm
Bolster Area (LRxFBxT)	450x300x50	540x320x60	610x425x70	685x480x70	760x530x80	800x560x90	1020x650x100
Bolster To Guide	250 mm	280 mm	320 mm	375 mm	425 mm	475 mm	525 mm
Bed Bore (LRxFB)	250x180	275x200	300x210	350x230	400x230	400x250	460x300
Ram Adjustment	25 mm	25 mm	25 mm	50 mm	50 mm	50 mm	50 mm
Center To Black	140 mm	150 mm	200 mm	230 mm	255 mm	265 mm	315 mm
SPM	50	50	40	35	30	25	20
Electric Motor HP/RPM	2/1440	2/1440	3/1440	5/1440	5/1440	7.5/1440	10/1440

POWER PRESSES

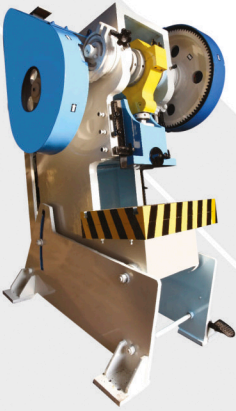

BSP Series, C Frame inclinable Power Press



BSS Series, H Frame Power Press



Pneumatic Clutch Power Press



Over Crank Shearing Machine



Pneumatic Clutch Power Press

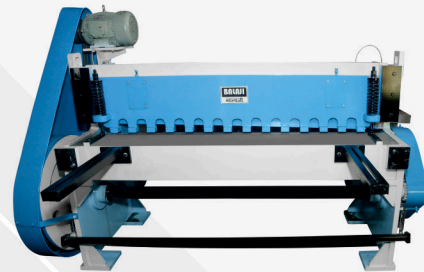

Under Crank Shearing Machine



BSP Series, Pneumatic Power Press



Powder Compacting Machine

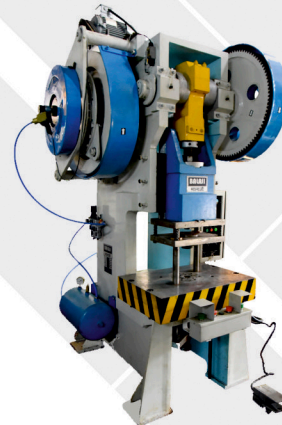

Pneumatic Clutch Sizing Machine



With our Diligent efforts & Hard work of Our Team, we are excellently Catering to the need of various industrial sectors all across country



Against Manufacturing Defect
(Limited Offer)

Manufactured by:

SHRI BALAJI ENGINEERING WORKS

D-83, Industrial Estate, Aligarh - 202 001

☎ +91 74173 92066, 94122 74912, 84106 46370

✉ sbewoffice@gmail.com

🌐 www.balajipowerpresses.com

Authorised Dealer